

AKVILE

Ugaona garnitura



OPREZ:

-Molimo vas da ne otvarate kompresovano pakovanje dok okvir vaše sofe nije potpuno sastavljen. - Kompresovani jastuci moraju se potpuno napuhati u roku od 72 sata kako bi se savršeno koristili. - Molimo vas da djecu držite podalje od plastičnih vrećica ili bilo kakvih malih predmeta. - Nakon što je sastavljanje završeno, ne zaboravite tapkati jastuke za naslon i sjedište kako bi se bolje oporavili. I pričekajte 72 sata da se potpuno oporave. - Jastuke treba redovno održavati radi savršene upotrebe. - Preporučuje se da instalaciju obavljaju 2 osobe.

- Dvije osobe trebaju podići sofau ako je želite pomaknuti, nemojte je gurati ili vući direktno

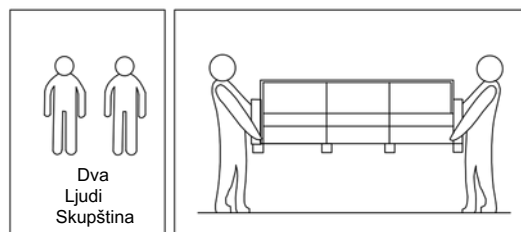

Komponente:

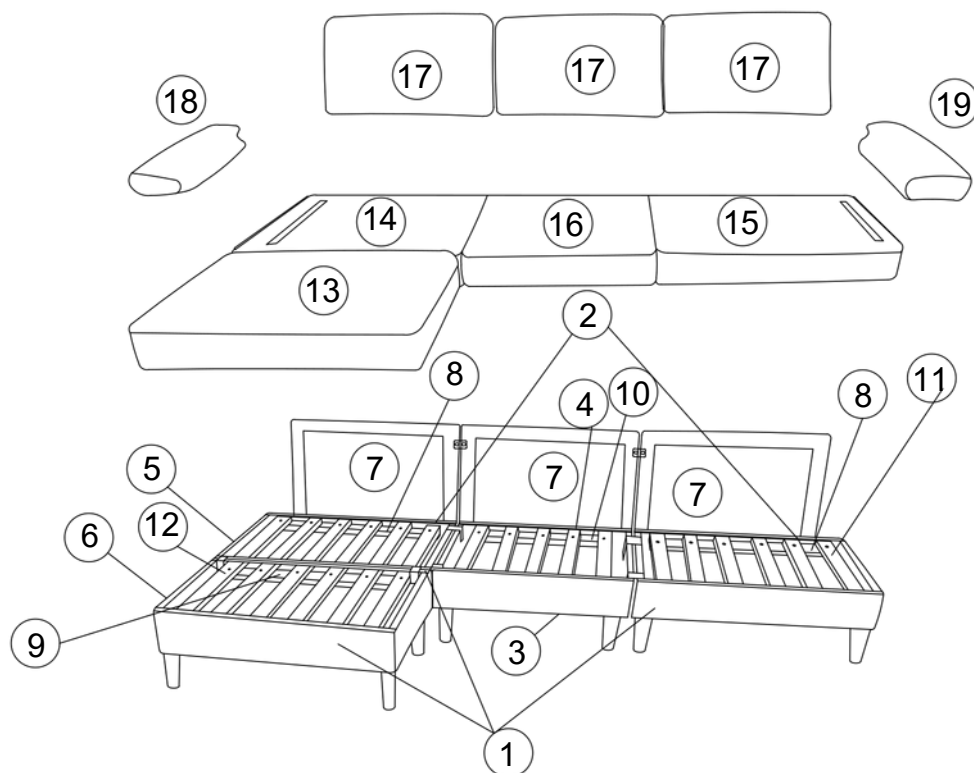

UPUTSTVO ZA SKLAPANJE

DIJELOVI:

1



Prednja ploča fotelja i
Prednja i zadnja ploča Ottoma
4 KOMADA

2



Zadnja ploča armcharisa
4 KOMADA

3



Prednja ploča srednje
stolice
1 KOMAD

4



Naslon srednje stolice
1 kom

5



Bočni panel naslon za ruku
stolice i srednja
stolica 6 kom

6



Bočna ploča otomana
2 KOMADA

7

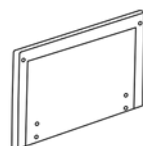

Okvir naslona sofe
3 KOMADA

8



Naslone za naslon fotelja
2 KOMADA

9



Prednji oslonac fotelje i
prednji i stražnji oslonac
otomane
4 KOMADA

10



Oslonac srednje stolice
2 KOMADA

11

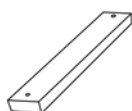

Kratke letvice stolice
17 KOMADA

12

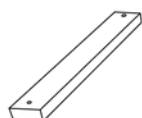

Otoman s dugim letvicama
6 KOMADA

13



Jastuk za sjedište od otomana
1 KOMAD

14

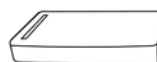

Jastuk za sjedište lijeve ruke
stolica
1 kom

15



Jastuk za sjedište desne ruke
fotelja
1 kom

16



Jastuk sjedišta
srednjeg dijela stolice
1 KOMAD

17



Jastuk za leđa
3 KOMADA

18



Naslonjač za ruku lijeve stolice
1 KOMAD

19



Jastuk za ruku desnog sjedišta
ruku
1 KOMAD

20

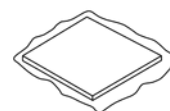

Tkanina za naslone za
stolice
2 KOMADA

21

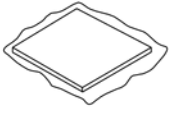

Platnena navlaka za
srednje stolice
1kom

22

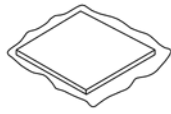

Navlaka za otoman od tkanine
1
kom

HARDVER

A

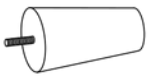

NOGA
16
KOMADA

B



Bracket
16
KOMADA

C



Metalni panel
2
KOMADA

D



M8*20mm
68 kom

I



M8*45mm
10 kom

F



M8*80mm
12
KOMADA

G



M 8mm
12 kom

H



M8x19x2
22
KOMADA

J

a

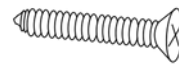

M4*40mm
46
KOMADA

J



Nosač u obliku slova U
6 KOMADA

K.



5#
1
kom

L



1
kom

M



1
kom

Sav pribor je zapakiran u 2 kutije i možda neće stići istovremeno.

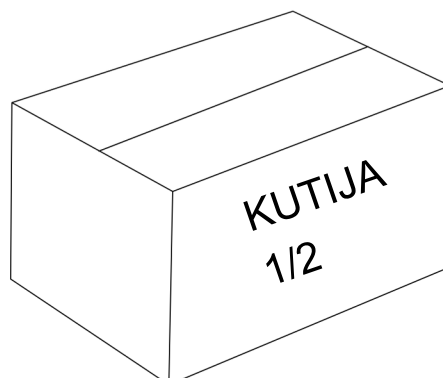

Kutija 1/2 sadrži: dio (1) x1, (2)x1, (3)x1, (4)x1, (5)x4, (7)x2, (8)x1, (9)x1, (10)x2, (11)x11, (15)x1, (16)x1, (17)x2, (20)x1, (21)x1.

i hardver (A)x8, (B)x8,(C)x1, (D)x34 (E)x4,(F)x8,(G)x8,
(H)x12,(I)x22,(J)x2,(K)x1,(L)x1,(M)x1.

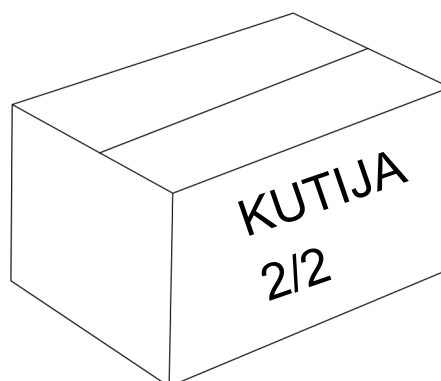

Kutija 2/2 sadrži: dio (1) x3, (2)x1,
(5)x2, (6)x2, (7)x1,
(8)x1, (9)x3, (11)x6, (12)x6, (13)x1, (14)x1,
(17)x1, (18)x1, (19)x1, (20)x1, (22)x1.

i hardver (A)x8, (B)x8, (C)x1, (D)x34 (E)x6,
(F)x4,(G)x4,(H)x10,(I)x24,(J)x4.

KORAK 1: Spojite ploču 1 i 4 pomoću nosača "B" i pričvrstite je vijcima. Ponovite isti postupak za osigurajte ostale panele.

Sastavite fotelju okrenutu prema lijevoj strani

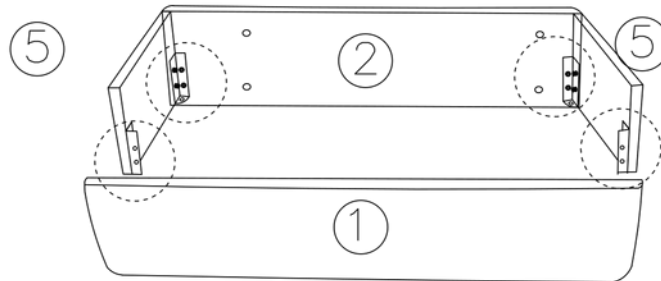
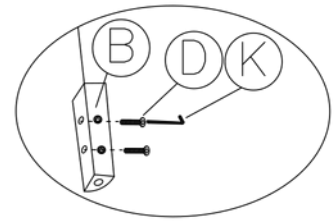

	B x 4
	K X 1
	D X 16

KORAK 2: Sastavite noge.
2:

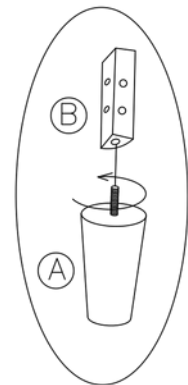
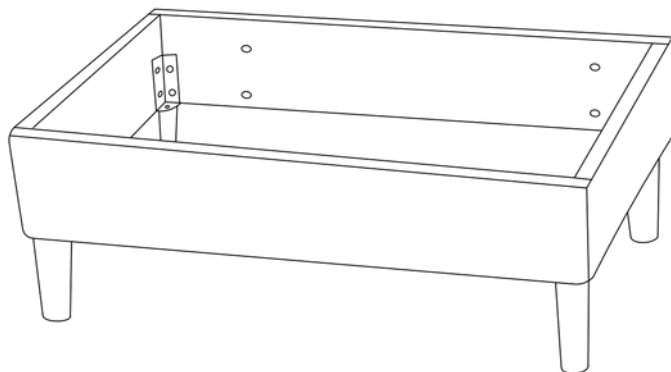

KORAK 3: Pričvrstite platnenu navlaku (20) na okvir sjedišta, strana s rupama je stražnja strana, poravnajte rupu, postavite poklopac na mjesto i zalijepite ga čičak trakom.

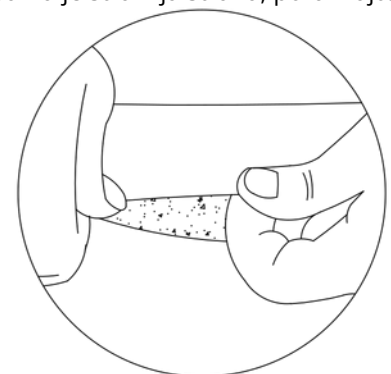
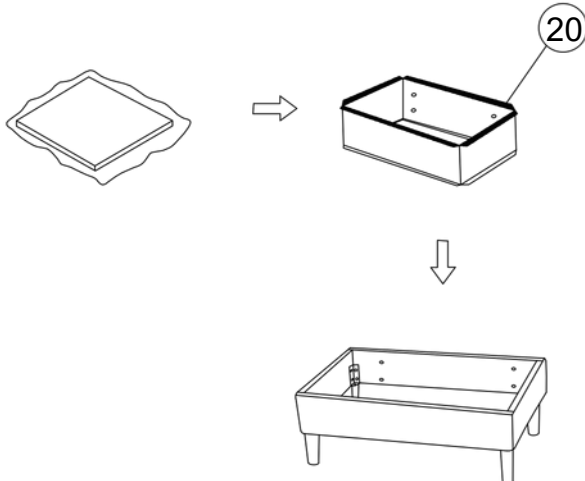



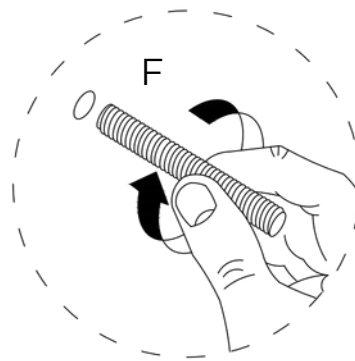
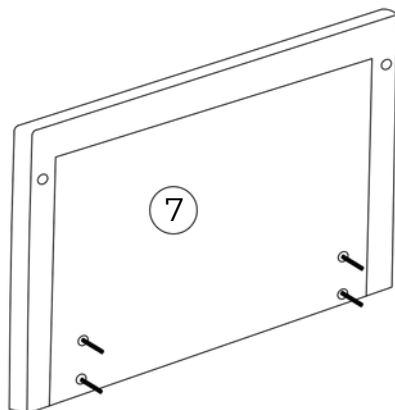

KORAK 4: Pričvrstite vijke u zadnji okvir oko 2 cm.

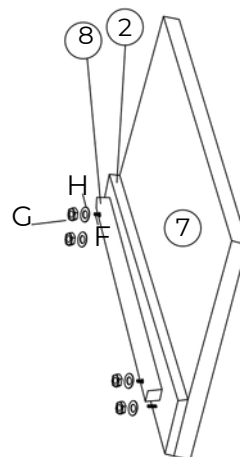
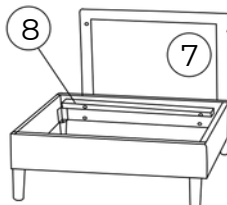
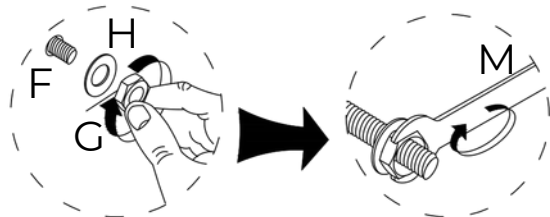

	F X 4
---	-------



KORAK 5: Umetnite naslon vijcima u okvir sjedišta i kroz drvenu potporu naslona ⑧ stavite podlošku, a zatim Zategnite matice ključem iznutra.



	V x 4
	G X 4
	M X 1

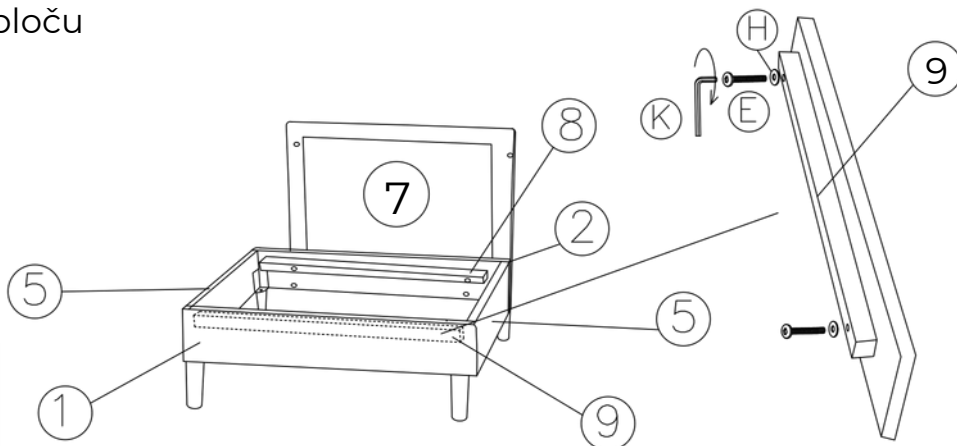

KORAK 6: Postavite prednju drvenu potporu ⑨ sa vijcima na prednju ploču

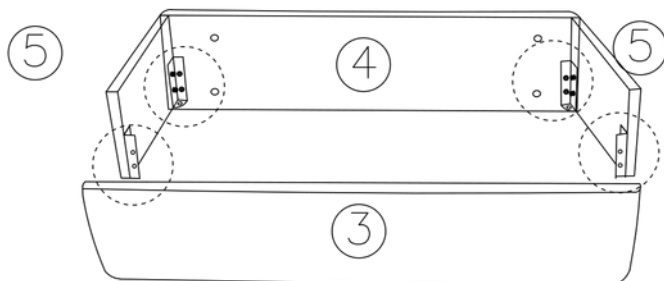
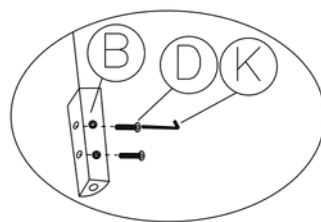

	V X 2
	K X 1
	E X 2

KORAK 7: Spojite ploču ③ i ⑤ pomoću nosača "B" i pričvrstite je vijcima. Ponovite isti postupak za ostale panele.



	B x 4
	K x 1
	D x 16

KORAK 8: Sastavite noge.

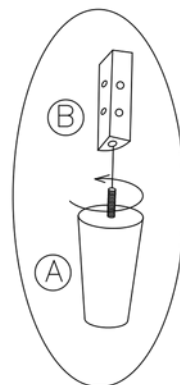
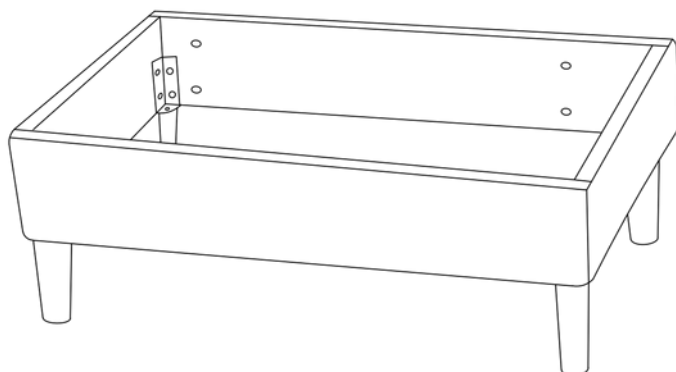

KORAK 9: Pričvrstite platnenu navlaku (21) na okvir sjedišta, strana s rupama je stražnja strana, poravnajte rupu, postavite poklopac na mjesto i zalijepite ga čičak trakom.

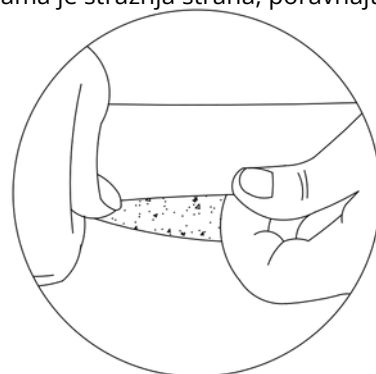
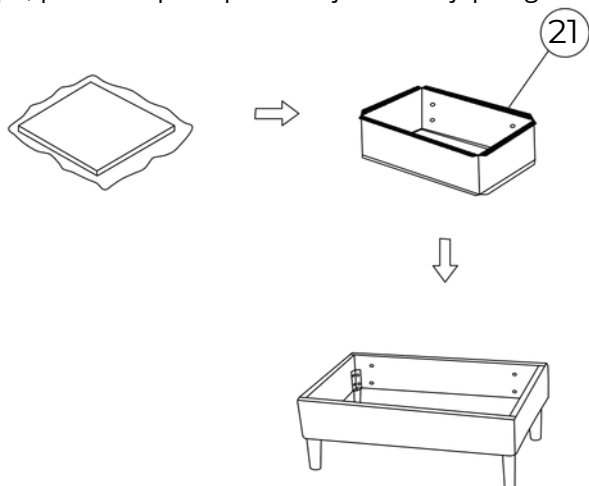

KORAK 10: Pričvrstite vijke u zadnji okvir oko 2 cm.

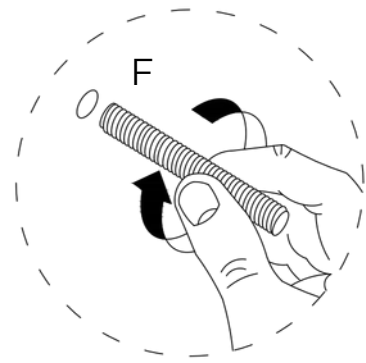
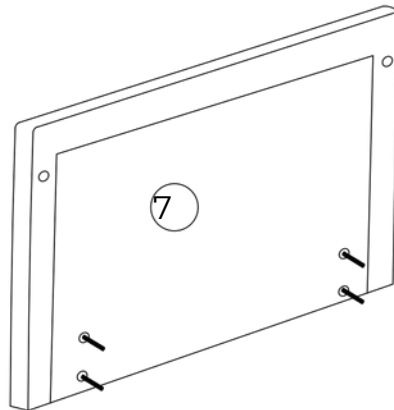

F X 4

KORAK 11: Umetnite naslon vijcima u okvir sjedišta i kroz drvenu potporu naslona (10) stavite podlošku, a zatim Zategnite matice ključem iznutra.

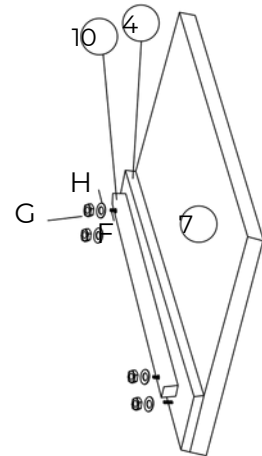
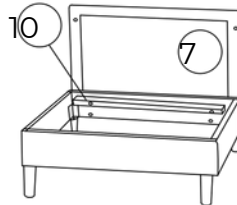
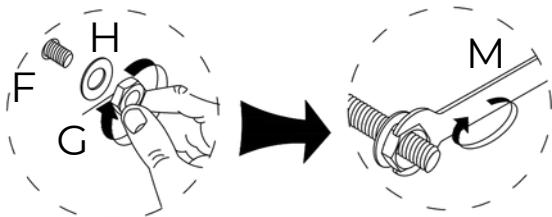

V x 4



G X 4



M X 1

KORAK 12: Postavite prednju drvenu podupirač(10) na prednju ploču pomoću vijaka.

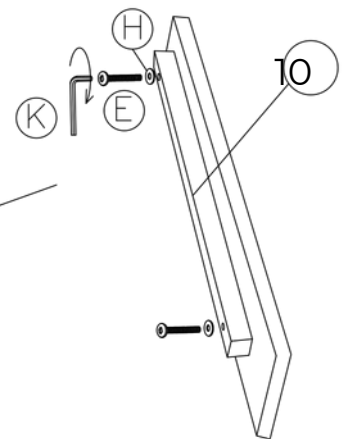
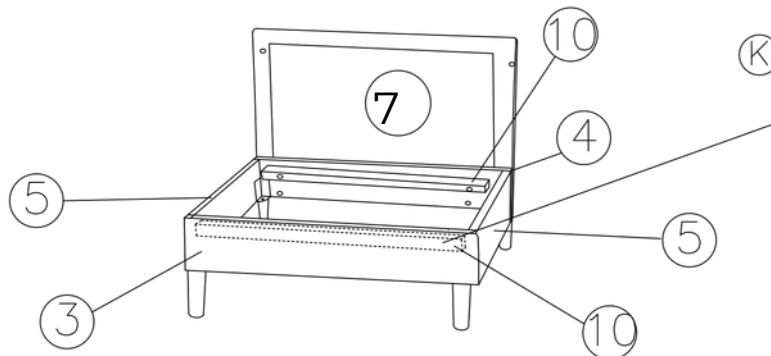

V X 2



K X 1







E X 2

Stranica 9

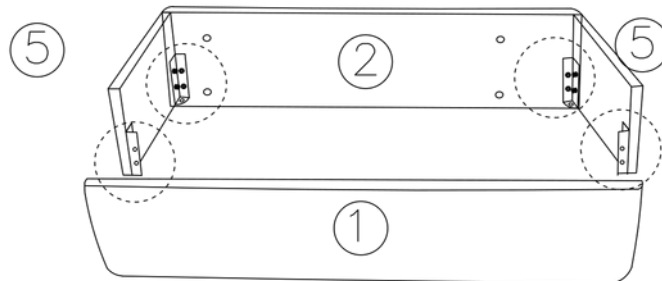
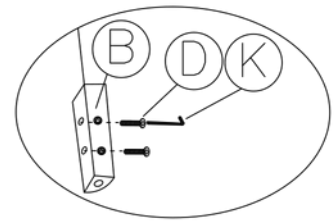
KORAK 13: Spojite ploču 1 i 4 pomoću nosača "B" i pričvrstite je vijcima. Ponovite isti postupak za osigurajte ostale panele.

Sastavite fotelju okrenutu udesno



	B x 4
	K X 1
	D X 16

KORAK 14: Sastavite noge.

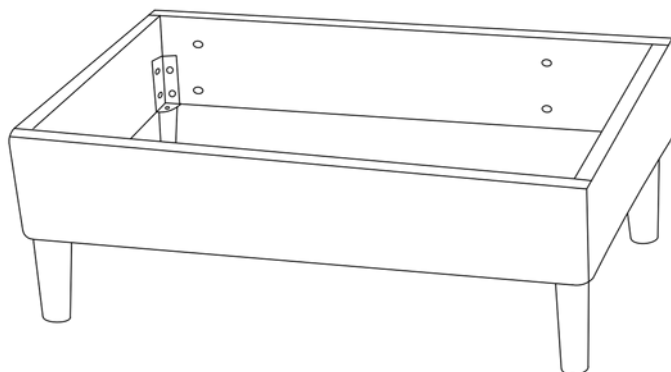
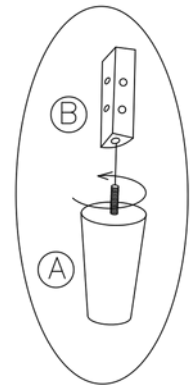

KORAK 15: Pričvrstite platnenu navlaku (20) na okvir sjedišta, strana s rupama je stražnja strana, poravnajte rupu, postavite poklopac na mjesto i zalijepite ga čičak trakom.

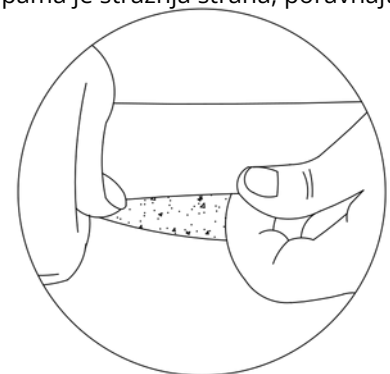
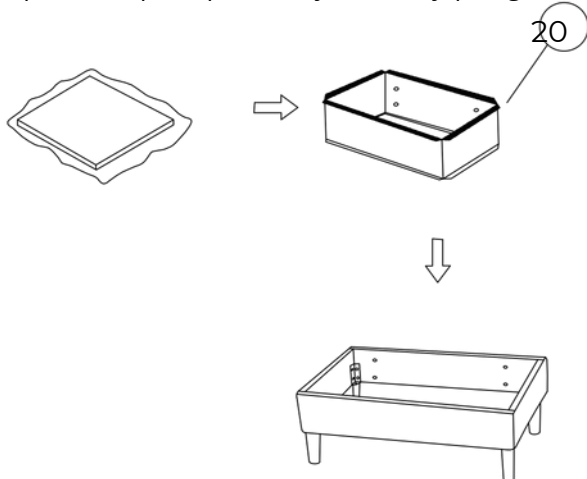



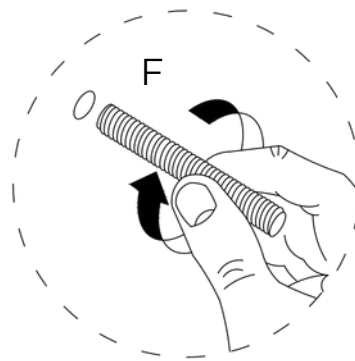
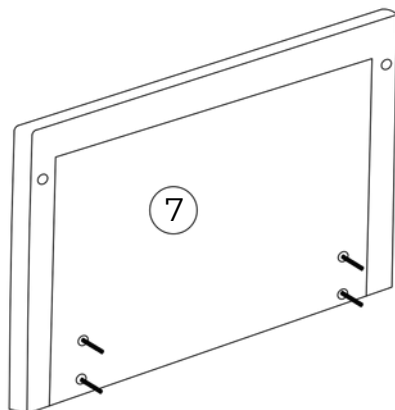

KORAK 16: Pričvrstite vijke u zadnji okvir oko 2 cm.

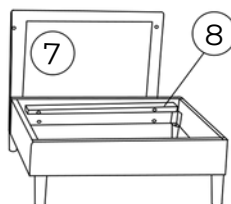
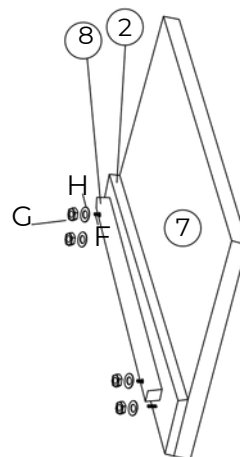
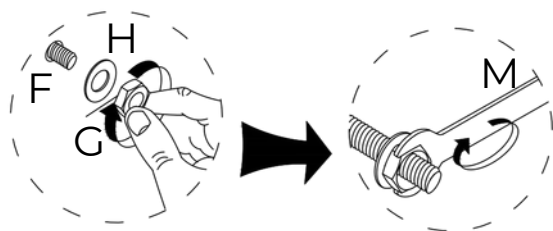

	F X 4
---	-------



KORAK 17: Umetnite naslon vijcima u okvir sjedišta i kroz drvenu potporu naslona ⑧ stavite podlošku, a zatim Zategnite matice ključem iznutra.

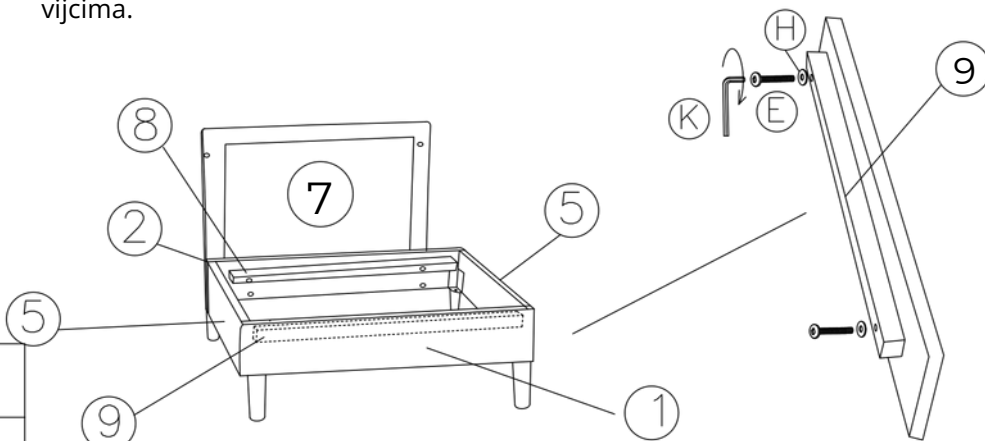

	V x 4
	G X 4
	M X 1

KORAK 18: Pričvrstite prednju drvenu podupirač ⑨ na prednju ploču vijcima.



	V X 2
	K X 1
	E X 2